



## CARACTERISTIQUES

Connexions fluide	<b>1" 1/4 BSP</b>
Connexions Air	<b>1/2" BSP</b>
Débit Max.	<b>250 lt/min</b>
Pression Air Max.	<b>8 bar</b>
Hauteur aspiration max.	<b>80 m</b>
Ht max aspiration à sec	<b>5 m</b>
Ht max aspir. mouillée	<b>9,8 m</b>
Ø passage solides Max.	<b>7,5 mm</b>
Niveau sonore	<b>75 dB</b>
Viscosité Max.	<b>35.000 cps</b>
Volume par coups	<b>700 CC</b>

- II 3/3 G Ex h IIB T4 Gb ~
- II 3 D Ex H IIB T135°C Db X

## POLYPROPYLENE

Le volume par coups peut varier en fonction des conditions d'aspiration, de la hauteur de refoulement, de la pression d'air et du type de fluide.



WEIGHT	TEMPERATURE	
<b>14,2 KG</b>	<b>-4°C</b>	<b>+65°C</b>

## PERFORMANCE

Les courbes et les performances se réfèrent à des pompes à aspiration immergée et refoulement libre, avec de l'eau à 20 °C. Ces données peuvent varier en fonction des matériaux de construction et des conditions hydrauliques.

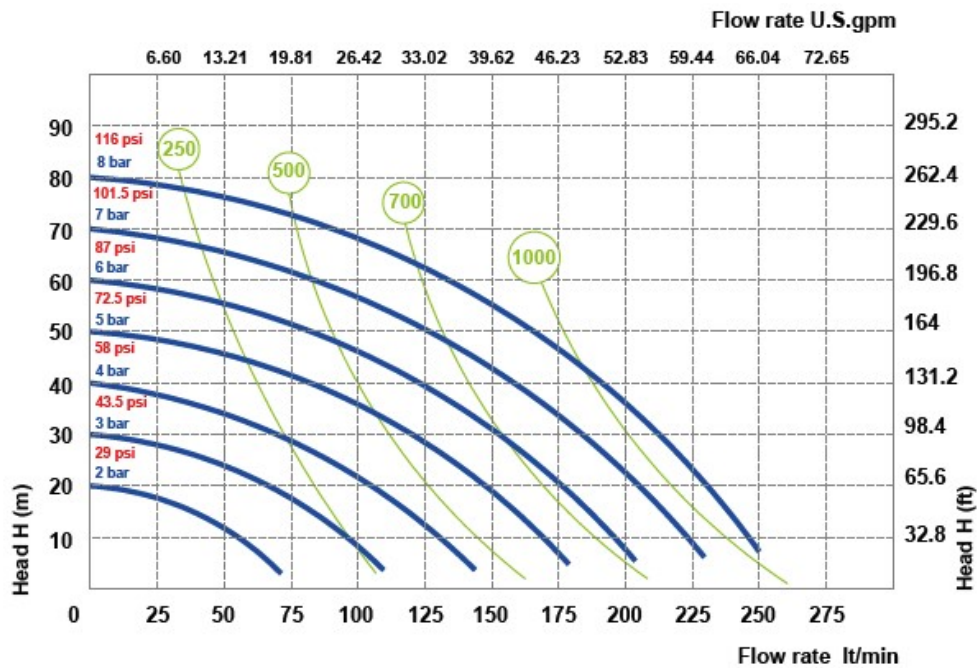

- Air supply pressure
- Air consumption Nlt/min



## COMPOSITION

MODELE	BOITIER	MEMBRANE	BILLES	SIEGES	JOINTS	CONNEXIONS	ATEX	SORTIES
P0252	P = PP	HT = HYTREL+PTFE MT = SANTOPRENE+PTFE H = HYTREL M = SANTOPRENE D = EPDM N = NBR	T = PTFE S = INOX D = EPDM N = NBR	P = PP S = INOX Z = PE	D = EPDM V = VITON N = NBR T = PTFE	1 = BSP 2 = BRIDE 5 = NPT	-- ZONE 2	AB = STANDARD

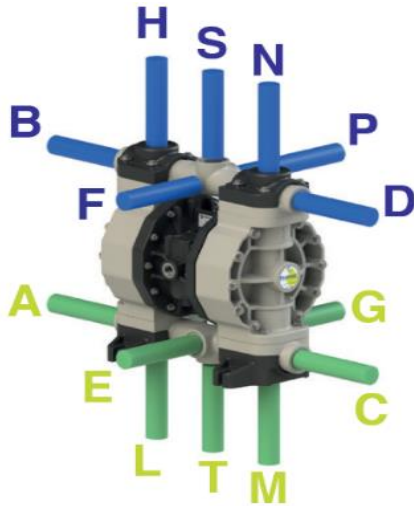

CONNEXIONS DISPONIBLES

**REFOULEMENT: B-D-F-P-S**

**ASPIRATION: A-C-E-G-T**

DIMENSIONS COLISAGE

BOITE CARTON: 43 x 27 x 45 cm

## DIMENSIONS

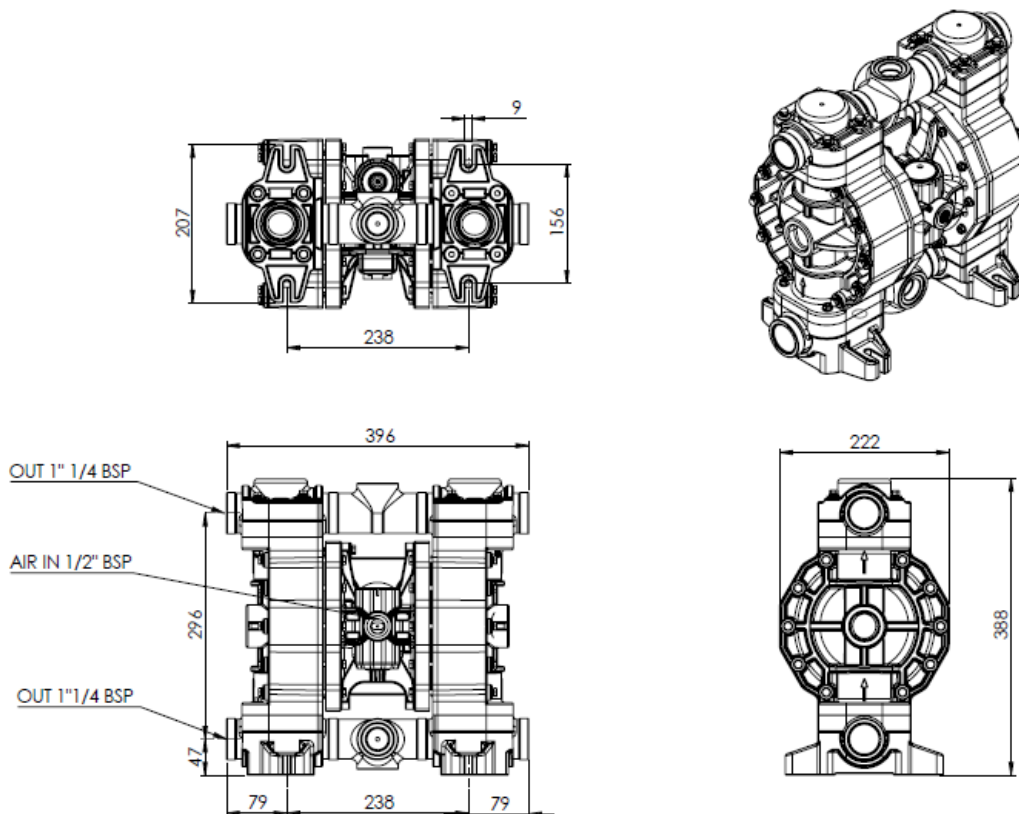

Technical data are approximate and not binding for the manufacturer who reserves the right to change them without notice at any time.

